

## Structural Chemistry inside Zeolite A

Karl Seff

*Department of Chemistry, University of Hawaii, Honolulu, Hawaii 96822*

*Received June 11, 1975*

Zeolites<sup>1</sup> are a class of aluminosilicates with relatively rigid anionic frameworks and crystallographically well-defined channels and cavities. These contain exchangeable cations and generally removable and replaceable guest molecules, such as water. The unusual properties of zeolites, also called molecular sieves, and their economy of synthesis have led to their wide utilization as catalysts, ion exchangers, and selective sorbing agents.

The three areas of chemistry that these properties indicate, catalysis, ion exchange, and sorption, have generally lacked definitive structural bases, and this has impeded a quantitative understanding of zeolite function. Zeolites are, however, crystalline, and their properties are proportional to volume, and not to features of the crystalline surface. The determination of the structures, then, of variously prepared, exchanged, modified, and complexed zeolites by the precise methods of single-crystal crystallography can provide much of the detailed structural information needed to complete a descriptive understanding of the function of zeolitic materials. More generally, however, these crystallographic results, by indicating the geometries of ion exchange, catalysis, and sorption sites and complexes, can also provide a structural basis for the quantitative description of these important properties in nonzeolitic materials and on surfaces.

### Intrazeolitic Coordination Chemistry

Zeolites are a remarkable medium in which to study coordination chemistry. The zeolite framework can be considered a rigid polydentate ligand within which the exchangeable cations must find suitable coordination sites without reorganizing their medium. This is a natural and (in a sense) infinite extension of the constraints of chelate coordination chemistry. It is not surprising, then, since zeolite morphology is governed by aluminosilicate structural considerations, that regular coordination polyhedra of proper size do not exist, in general, for exchangeable cations in dehydrated zeolites. Still, the ions must locate somewhere, so they "select the best sites they

can", resulting as a rule in extreme and unusual coordination numbers and geometries. These cations with unsatisfied ligancy are generally coordinatively unsaturated, and are the source of some of the zeolite's most interesting and commercially important properties.

To relieve coordinative unsaturation, at least partially, relatively weak complexes form readily within the zeolite where they can be studied crystallographically. This is in contrast to the situation in most crystalline materials which, as they form from solution for example, usually segregate weak solution-style interactions from their structures. As a result, crystallographers have had difficulty finding structures which model those of solvated cations in solution. For example, crystals of  $\text{Cu}(\text{CH}_3\text{CN})_4\text{Cl}$  do not form, but those of  $\text{CuCl}$  do, from saturated  $\text{CH}_3\text{CN}$  solution, and crystallography cannot tell us about the lengths of the  $\text{Cu(I)-N}$  or  $\text{C-N}$  bonds in that complexed cation. However,  $\text{CH}_3\text{CN}$  or  $\text{HCN}$  could be introduced into the  $\text{Cu(I)}$  form of a zeolite, and the bond lengths could be readily determined. Similarly, at least fractions of the solvation spheres of many other ions can be observed intrazeolitically. One may include  $\text{Fe(II)-O}_2$ ,  $\text{Ru(II)-N}_2$ , and  $\text{Co(II)-NO}$  as plausible and provocative additions to this list of complexes. This can be considered chemistry within a container approximately 10 Å on an edge, an exciting dimension from the viewpoint of solution chemistry.

### Crystallographic Considerations

It is important to stress the unusual facility with which such structures are determined. The positions of the atoms that comprise the aluminosilicate framework are known quite accurately from previous structure determinations. For centrosymmetric zeolites, as all the large-pore ones are, at least approximately, these atoms are usually sufficient to determine nearly all of the crystallographic phases. The framework can therefore be refined by least-squares immediately, unless very heavy atoms have been introduced into the structure. The first three-dimensional Fourier function, with phases from previous structures, contains nearly all the detail that is found on the last, phased with all cations and locatable sorbed atoms, if any, in refined positions. The step of "solving" a structural problem, still at least a chore in

Karl Seff was raised on a chicken farm in Petaluma, Calif. He received his B.S. degree from University of California, Berkeley, and the Ph.D. from Massachusetts Institute of Technology with D. P. Shoemaker, in 1964. Following 3 years of postdoctoral work in crystallography with K. N. Trueblood at UCLA, he joined the faculty of University of Hawaii, where he is professor of chemistry. In addition to his work on the structures of variously modified zeolite A, he has studied organic disulfides and their transition-metal complexes.

(1) D. W. Breck, "Zeolite Molecular Sieves", Wiley, New York, N.Y., 1974.

crystallography, is usually unnecessary in these studies.

Many potentially interesting structural investigations are effectively stymied because suitable single crystals cannot be grown. This problem, too, is bypassed in the study of intrazeolitic complexes. The crystals of the product to be studied have been prepared, or, if natural, have been found, beforehand. If the exchange, dehydration, and complexation procedures employed have not damaged the crystals, then no major hurdles obstruct the successful completion of the work. Often interesting structural problems cannot be studied crystallographically because the desired composition, corresponding to a structure proposed in solution, or on a surface, or in the gas phase, for example, is not represented by a stable solid phase. Beyond that, the experimental problems of preparing and handling air-sensitive single crystals often discourage further work. A zeolite single crystal, however, can readily be maintained with a Pyrex system throughout the ion-exchange, dehydration, sorption, and x-ray diffraction steps without exposure to the atmosphere. To a substantial degree, its composition can be considered tunable.

Finally, the high symmetry of the zeolites with the largest channels and cavities allows the unique diffraction data sets to be particularly small, usually 100 to 400 reflections, so that complete data can be collected relatively quickly and precisely. The number of parameters needed to describe the structures adequately is correspondingly small, and all of the required crystallographic calculations become uncrystallographically brief and inexpensive. Any structural hypothesis can be checked with several cycles of full-matrix least squares of the whole structure for approximately U.S. \$1. per cycle using, for example, an IBM 370 computer and a space-group general program.

Unfortunately, a severe, sometimes oppressive, problem limits the precision of the structures of and within large-pore zeolites. Minor but extensive disorder often results in physically unreasonable (by a small amount) thermal parameters for some of the major atomic positions in the structures. This disorder produces confusing ripples and false peaks on difference Fourier functions. The estimated standard deviations of the final parameters are often unusually high. These problems are due to true or assumed (in the choice of space group) disorder among Al and Si ions of the zeolite framework, partial occupancy of positions by cations and sorbed molecules (which usually extend the disorder of the zeolite framework), and deviations from ideal stoichiometry which occur easily in most zeolites. In assigning atoms to positions of partial occupancy, chemical considerations must be resorted to: these involve the maintenance of suitable interatomic distances, the assumption of highest possible symmetry, and the dismissability where possible of the most implausible chemical interactions. In most cases, the full three-dimensional structure is not determined, although some clear results, usually all those of primary chemical importance for a well-chosen problem, are achieved. Many crystallographers correctly judge such work to be well below conventional crystallographic standards, and it is not surprising that many find it unsatisfying. It is

difficult to include enough disclaimers in each report of a zeolitic structure, or to produce drawings whose assumptions and limitations are appreciated by all readers.

To minimize these problems, zeolites whose framework compositions are stoichiometric should be used. Ion exchange should be complete or stoichiometric. Sorbed molecules should be present in stoichiometric numbers per unit cell. The cations present should occupy as few crystallographic sites as possible, filling most of them to the highest extent possible. Natural crystals, which are usually badly nonstoichiometric, are therefore disfavored, although the relatively large single crystals available have made some studies feasible. Faujasite and its synthetic counterparts, zeolites X and Y, have been attractive because their large pores and their thermal and chemical stability have given these materials unusual commercial importance. However, in that zeolite, many cation sites exist, most of which are occupied at small fractional levels, and the crystallographic problems presented by complexation have, to date, been surmounted only for water,<sup>2</sup> or have been unsurmountable, or have been cautiously avoided.

Zeolite A, the first synthetic zeolite to be prepared,<sup>3</sup> is the zeolite of choice. The framework Si/Al ratio is 1.0 in conventional preparations. Eleven of the twelve univalent cations per unit cell fully occupy (in a sense) two crystallographic sites, leaving only the one remaining cation to be disordered within a third equipoint. Upon ion exchange with four or more bivalent cations, to give eight or fewer exchangeable ions per unit cell, all the ions of each chemical type are generally equivalent. The structure of zeolite A is simple enough for all ions and water molecules to be locatable, and for estimated standard deviations to be low in comparison to those of other zeolites. For these reasons, only zeolite A has been studied in this laboratory, and the results to be presented have been learned from the study of that zeolite alone, although they have a degree of generality that extends to other zeolites, and to other crystalline and amorphous materials, and to surfaces, of similar composition.

### Structure of Zeolite A

All structures will be discussed in the cubic space group  $Pm\bar{3}m$ . The formula per unit cell is  $\text{Na}_{12}\text{Al}_{12}\text{Si}_{12}\text{O}_{48}\cdot 27\text{H}_2\text{O}$  in the form in which zeolite A is synthesized, and should be considered as follows: the 12  $\text{Na}^+$  ions are ion exchangeable;  $\text{Al}_{12}\text{Si}_{12}\text{O}_{48}^{12-}$  comprises a relatively rigid anionic framework in the zeolite A arrangement, and the water molecules can be baked out to leave intracrystalline volume into which other guest molecules can be sorbed. The conventional name<sup>4</sup> would be  $\text{Na}[\text{AlSiO}_4]27\text{H}_2\text{O}-\text{A}$ , but the name hydrated  $\text{Na}_{12}-\text{A}$ , and nomenclature of that style for otherwise ion-exchanged or complexed samples, will be used here because the exchangeable cation composition per unit cell is explicit, and because the zeolite framework composition is constant throughout.

The structure of dehydrated  $\text{Na}_{12}-\text{A}^5$  is shown in

(2) Reviewed by J. V. Smith, *Adv. Chem. Ser.*, No. 101, 171 (1971).

(3) D. W. Breck, W. G. Eversole, R. M. Milton, T. B. Reed, and T. L. Thomas, *J. Am. Chem. Soc.*, 78, 5963 (1956).

(4) R. M. Barrer, informal presentation, Third International Conference on Molecular Sieves, Zurich, 1973.

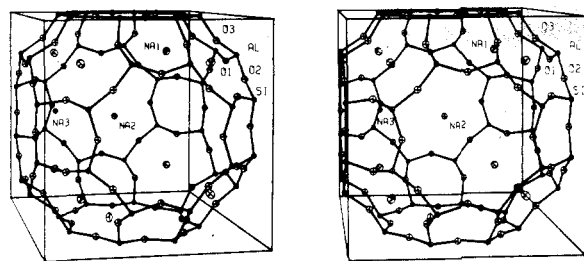

Figure 1. Stereoview<sup>6</sup> of dehydrated  $\text{Na}_{12}\text{-A}$  using 20% probability ellipsoids. The large cavity, or  $\alpha$  cage, is shown. All  $\text{Na}^+$  ions have unusual association environments.

Figure 1. The origin is selected at the center of the sodalite unit (sometimes referred to as the  $\beta$  cage), which is accordingly not clearly shown in the drawing because one-eighth of it is at each corner of the figure. The large cavity is clearly shown, however, and will serve to illustrate most of the structural chemistry to be discussed. The space group  $Pm\bar{3}m$  has an alternate choice of origin which, in this structure, is at the center of this large cavity (sometimes referred to as the  $\alpha$  cage). Each unit cell has one large cavity and one sodalite cavity; each cavity is approximately spherical with mean free diameters when empty of 11.4 and 6.6 Å respectively.

Entry into each large cavity can be made from six others, arranged octahedrally, through 16-membered  $\text{Al}_4\text{Si}_4\text{O}_8$  rings. The mean free diameter of this ring is approximately 4.2 Å and is defined by the ionic radii of the oxide ions—for this reason it is called an 8-ring (or an 8-window). Each sodalite cavity is surrounded cubically by eight large cavities, and can be entered from each only through a 2.2-Å 12-membered  $\text{Al}_3\text{Si}_3\text{O}_6$  6-ring. Exchangeable cations generally select positions near the centers of these rings, impeding the diffusion of molecules and other ions through the zeolite and decreasing effective ring diameters. Structural and chemical similarities to crown-ether complexes are apparent.

An exchangeable cation generally prefers a site near a 6-ring center close to three of the six oxygens, but displaced by a small distance along the 3-axis perpendicular to the ring. If there are more than eight cations per unit cell (such that all 6-rings are occupied), or if the cation is univalent and particularly large, 8-rings are occupied. Usually an 8-ring cation lies in the plane of that ring (all eight oxygens lie on a mirror plane), but displaced off-center so as to be in ionic contact with only two (related by a 4-axis) oxide ions of the 8-ring.

### Transition-Metal Ion Forms

The crystal structure of hydrated  $\text{Co}_4\text{Na}_4\text{-A}$ <sup>7</sup> illustrates the power of the method well with an important and entirely unexpected structural result. Three of the four water molecules coordinated to each of three  $\text{Co(II)}$  ions have also joined the coordination sphere of an aluminum ion of the zeolite framework (see Figure 2) to give five-coordinate  $\text{Al(III)}$ . (The possibility that this is a silicon ion is dismissed as

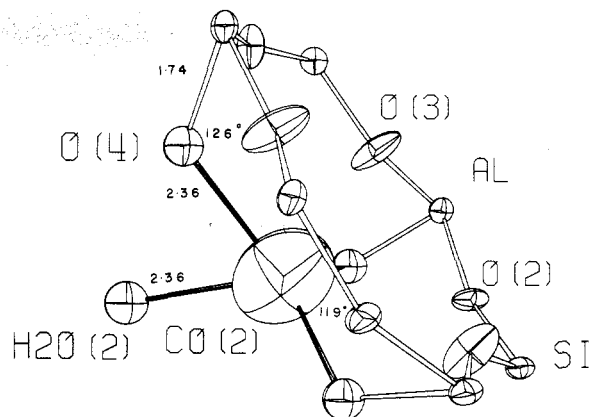

Figure 2. The coordination of a large-cavity  $\text{Co(II)}$  ion in the vicinity of its 6-ring in hydrated  $\text{Co}_4\text{Na}_4\text{-A}$ . Ellipsoids of 50% probability are used.<sup>6</sup> Each Al and Si atom makes two other bonds to oxygens which are not shown. Aluminum, then, is five-coordinate.

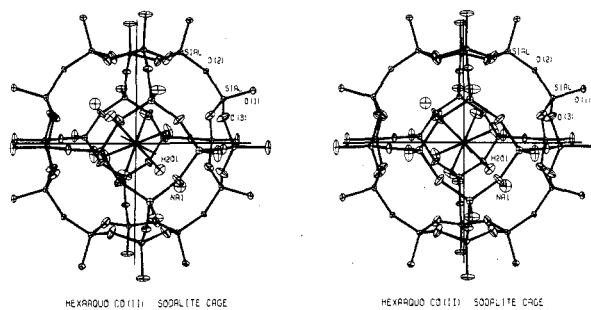

Figure 3. Stereoview<sup>6</sup> of hexaaquacobalt(II) in the sodalite cage using ellipsoids of 50% probability. Every hydrogen atom, not shown, can form a hydrogen bond of 2.85 Å to a zeolite framework oxygen.

chemically implausible.) The result is that nine of the twelve Al(III) ions per unit cell have become five-coordinate, and that at least nine protons have been produced by the dissociation of coordinated water, to avoid  $\text{AlCoH}_2$  coordination about oxide ions. Perhaps this is exactly the mechanism which allows transition-metal-exchanged zeolites to be valuable and effective Bronsted acid catalysts when incompletely dehydrated. The contribution of this structural work is (1) the observation of extensive five-coordinate Al(III) in the zeolite and (2) the dismissal of a direct addition reaction of  $\text{H}_2\text{O}$  to a Si-O-Al linkage to give a Si-OH and an Al-OH group—this has often been suggested to be a source of Bronsted acid sites in the zeolite. To complete the structure, a hexaaquacobalt(II) ion is located at the center of each sodalite unit (Figure 3) where it readily forms 12 hydrogen bonds to oxide ions of the zeolite framework; four  $\text{Na}^+$  ions and the remaining water molecules have been located.<sup>7</sup>

While somewhat more than four  $\text{Co(II)}$  ions can be readily exchanged into zeolite A from 0.1 M aqueous  $\text{Co(NO}_3)_2$  solution at room temperature, we have been unable to exchange more than 2.5 Ni(II) ions into hydrated  $\text{Na}_{12}\text{-A}$  under analogous mild conditions. Accordingly, the structural results<sup>8</sup> have been less detailed. However, it is clear that a fully aquated Ni(II) ion is located at the center of the sodalite unit as in Figure 3, while the remaining 1.5 Ni(II)'s per unit cell are almost exactly where the three  $\text{Co(II)}$ 's

(5) R. Y. Yanagida, A. A. Amaro, and K. Seff, *J. Phys. Chem.*, **77**, 805 (1973).

(6) C. K. Johnson, ORTEP, Report ORNL-3794, Oak Ridge National Laboratory, Oak Ridge, Tenn, 1965.

(7) P. E. Riley and K. Seff, *J. Phys. Chem.*, **79**, 1594 (1975).

(8) C. L. Kovaciny, M.S. Thesis, University of Hawaii, 1973.

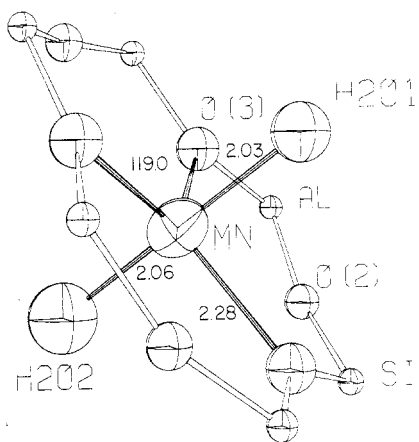

**Figure 4.** A Mn(II)-containing 6-ring in hydrated  $\text{Mn}_{4.5}\text{Na}_3\text{-A}$ . Ellipsoids of 20% probability are used.<sup>6</sup> The Mn(II) ion is five-coordinate, and nearly has  $D_{3h}$  symmetry.

were located, presumably for the same reasons, involving the formation of five-coordinate Al(III).

In contrast, neither the Mn(II) ions in hydrated  $\text{Mn}_{4.5}\text{Na}_3\text{-A}$ <sup>9</sup> nor the Zn(II) ions in hydrated  $\text{Zn}_5\text{Na}_2\text{-A}$ <sup>10</sup> have caused the coordination numbers of some Al(III) ions to be altered, and therefore neither has used this mechanism to produce protons in stoichiometric numbers. Mn(II) has selected a 6-ring site where it coordinates trigonally to three framework oxygens in a plane, and to two axial water molecules above and below that plane (Figure 4). Thus, five-coordinate trigonal-bipyramidal Mn(II) has formed easily, within zeolite A, by the mild process of room temperature ion exchange from aqueous 0.1 M  $\text{Mn}(\text{NO}_3)_2$ . All Mn(II) ions are equivalent; a hydrated Mn(II) ion is not found in the sodalite unit.

In hydrated  $\text{Zn}_5\text{Na}_2\text{-A}$ ,<sup>10</sup> one tetraaquazinc(II) ion is located at the center of the sodalite unit where it can form eight hydrogen bonds to oxide ions of the framework. The remaining Zn(II) ions are equivalent and are each tetrahedrally surrounded by three framework oxygens and one water molecule. These coordination geometries for Zn(II) are not unusual.

Dehydrated  $\text{Mn}_{4.5}\text{Na}_3\text{-A}$ <sup>9</sup> and  $\text{Co}_4\text{Na}_4\text{-A}$ <sup>11</sup> can be readily prepared from the hydrated forms; the conditions 350 °C and  $10^{-5}$  Torr for 24 h are more than adequate. In each structure, all bivalent cations are three-coordinate (see Figure 5) and lie on 3-axes near the centers of the 6-rings. Approximately one-half sphere of solid angle is available at each of these ions for complexation by guest ligands which may be sorbed into the zeolite. To relieve this extreme state of coordinative unsaturation, weak or otherwise unusual coordination complexes form and can be observed crystallographically.

The same dehydration procedure applied to fully hydrated  $\text{Zn}_5\text{Na}_2\text{-A}$ <sup>10</sup> yields a structure with four residual water molecules per unit cell: three in the large cavity, each completing a near-tetrahedral coordination sphere for one Zn(II) ion, and one in the sodalite unit, bridging between two Zn(II) ions and complet-

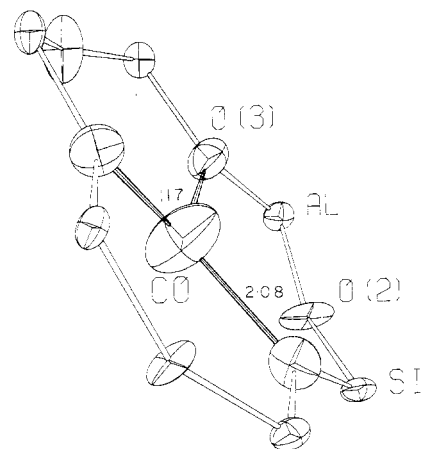
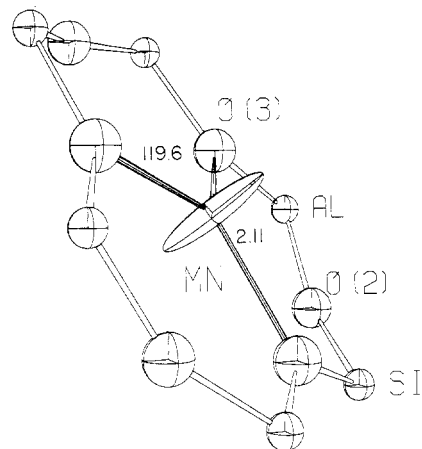

**Figure 5.** When  $\text{Mn}_{4.5}\text{Na}_3\text{-A}$  and  $\text{Co}_4\text{Na}_4\text{-A}$  are dehydrated, all transition-metal ions become three-coordinate in the 6-rings. Ellipsoids of 20% (top) and 50% (bottom) are shown.<sup>6</sup> The Mn(II) thermal ellipsoid probability represents an average over two Mn(II) positions, one on each side of the 6-ring.

ing their near-tetrahedral coordination spheres. This last water oxygen, with a  $\text{H}_2\text{Zn}^{II}_2$  coordination sphere, has presumably dissociated at least one proton and should have some Bronsted activity. Similar dehydration of  $\text{Zn}_5\text{Na}_2\text{-A}$  at approximately 430 °C leaves this single water oxygen and the two Zn(II) ions associated with it unaffected.<sup>10</sup> The remaining three water molecules are removed, however, and the three corresponding Zn(II) ions have moved toward the plane of their remaining three nearest neighbors, framework oxygens of the 6-rings, to become three-coordinate.

Similar dehydration of  $\text{Zn}_5\text{K}_2\text{-A}$  at 400 °C results in a structure<sup>12</sup> in which approximately 1.5 Zn(II) ions are three-coordinate, while the rest continue to hold one water molecule each, mostly in the large cavity. The  $\text{K}^+$  ions are associated with the 8-rings of this structure, in contrast to the 6-ring sites selected by the  $\text{Na}^+$  ions in  $\text{Zn}_5\text{Na}_2\text{-A}$ .

The dehydration of  $\text{Ni}_{2.5}\text{Na}_7\text{-A}$  produces a black material<sup>8</sup> with an ESR spectrum indicative of metallic Ni(0). Ni(III) or Ni(IV) ions, the oxidized products of Ni(II) disproportionation, are found relatively deep in the sodalite unit where they may bridge through a single oxide ion from a now-dissociated water molecule. Klier reports that a higher degree of

(9) R. Y. Yanagida, T. B. Vance, Jr., and K. Seff, *Inorg. Chem.*, **13**, 723 (1974).

(10) A. A. Amaro, R. Y. Yanagida, and K. Seff, unpublished work.

(11) P. E. Riley and K. Seff, *Inorg. Chem.*, **13**, 1355 (1974). In a preliminary report (P. E. Riley and K. Seff, *J. Chem. Soc., Chem. Commun.*, 1287 (1972)), the  $\text{Na}^+$  and  $\text{Co}^{II}$  positions were interchanged and were refined to incorrect coordinates.

(12) N. V. Raghavan and K. Seff, Northwest Regional Meeting of the American Chemical Society, Honolulu, Hawaii, June 1975; submitted for publication in *J. Phys. Chem.*

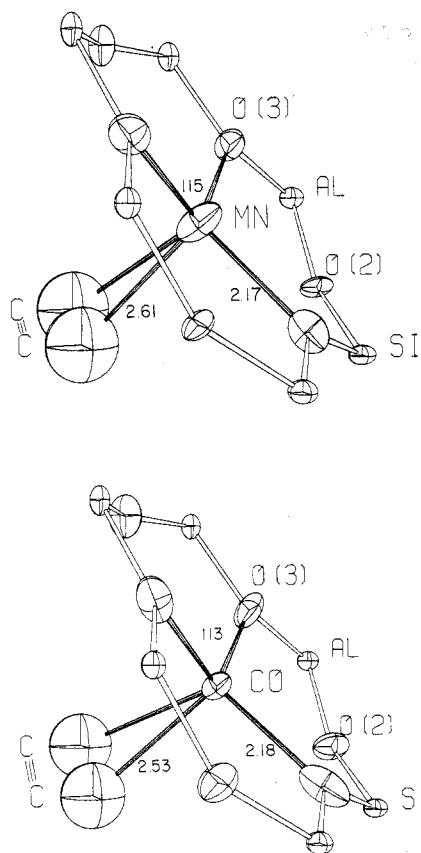

**Figure 6.** Three-coordinate Mn(II) (top) and Co(II) (bottom) readily form weak complexes with acetylene. These cations have shifted about half way toward a tetrahedral position on the large cavity side of the 6-rings upon complexation. In each structure, the two metal-to-carbon distances are equal, and in neither does the C-C bond intersect the 3-axis of the 6-ring.

exchange is possible, and finds yellow dehydrated Ni(II)-exchanged zeolite A whose Ni(II) ions are three-coordinate.<sup>13</sup> This discrepancy has not been resolved.

### Sorption Mechanisms

The hydrated and dehydrated structures of  $Mn_{4.5}Na_3-A$ ,<sup>9</sup> to select one example from among many, offer an insight into the process of sorption. In the hydrated form, the zeolite framework angles at oxygen differ by  $2^\circ$  or less from those in hydrated  $Na_{12}-A$ ,<sup>14</sup> the form in which zeolite A is synthesized. Upon dehydration, the largest difference is  $20^\circ$ , and the zeolite can be considered relatively strained mechanically. The process of rehydration, then, gains an additional free-energy contribution by relaxing the zeolite framework. Other sorbed molecules generally cause the zeolite framework to relax also, at least partially, as they begin to satisfy the ligancies of the cations. Since structural models indicate that mechanical deformations are not well localized in zeolite A, cooperative sorption, where the heat of sorption of some subsequent molecules is modified by the sorption of previous ones, is to be expected.

A second lesson is here to be learned. In hydrated  $Mn_{4.5}Na_3-A$ ,<sup>9</sup> the equatorial Mn(II)-O (oxide) distances are 2.28 Å, and the axial Mn(II)-O (water) distances are 2.06 Å. The neutral ligand is able to ap-

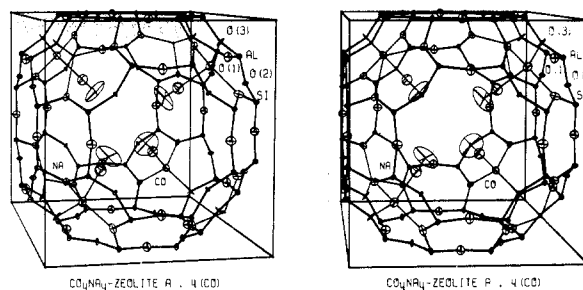

**Figure 7.** A stereoview of the CO complex of  $Co_4Na_4-A$  with ellipsoids of 20% probability.<sup>6</sup> The carbon atoms are coordinated to Co(II), and the oxygen atoms have high thermal motion perpendicular to the CO bond.

proach Mn(II) much more closely in this zeolite system than is the framework oxide ion, despite the formal negative charge of the latter (see Figure 4). Apparently the Mn(II) ions participate in no interactions stronger than those with the sorbed molecules. This has occurred, in part, because it is only these sorbed ligands which can be positioned in the transition-metal's coordination sphere according to its electronic preferences, without seriously compromising, as the framework oxygens must, with the steric requirements of the relatively rigid zeolite. Other sorbed-molecule-transitional-metal-ion coordination interactions can be expected to be particularly strong within zeolites for this reason.

### Sorption Complexes

Acetylene at 700 Torr and room temperature was allowed to reach equilibrium with the dehydrated zeolites  $Na_{12}-A$ ,<sup>15</sup>  $Mn_{4.5}Na_3-A$ ,<sup>16</sup> and  $Co_4Na_4-A$ .<sup>16</sup> Ethylene was similarly introduced to  $Co_4Na_4-A$ .<sup>17</sup> All sorbed molecules (6, 4.5, 4, and 4, respectively) approach cations laterally and relatively symmetrically (see Figure 6 for two examples) to give two 2.6-Å M(II)-C distances per M(II) ion, and 2.6 to 3.0 Å  $Na^+-C$  distances in  $Na_{12}-A$ . The sorption mechanism appears to be charge-to-induced-dipole in nature, involving the polarizable  $\pi$  orbitals of the unsaturated hydrocarbons. In each case the coordinated cation moves toward the center of its new coordination polyhedron, but not the entire distance, because the new ligand is still distant and relatively weakly held.

The sorption of CO under the same conditions using initially deep-blue dehydrated  $Co_4Na_4-A$  yielded  $(Co-CO)_4Na_4-A$ <sup>11</sup> which was unchanged in color. The angle C-O-C is  $180^\circ$  (Figure 7), and the Co(II) ion has adjusted its position toward the center of its new coordination sphere. The Co(II)-C distance, 2.3 Å, is 0.5 Å longer than that found in cobalt(0) carbonyls, presumably because the contracted d orbitals of Co(II) effectively eliminate the possibility of synergic  $\pi$  back-bonding to empty metal orbitals.

A similar experiment using NO at 10 Torr yields  $(Co-NO)_4Na_4-A$ <sup>18</sup> which is dark brown, suggesting an electronic rearrangement at Co(II), perhaps to give Co(III) and  $NO^-$ . The CoNO angle (Figure 8) is approximately  $140^\circ$  and the bond lengths are quite im-

(15) A. A. Amaro and K. Seff, *J. Phys. Chem.*, **77**, 906 (1973).

(16) P. E. Riley and K. Seff, *Inorg. Chem.*, **14**, 714 (1975).

(17) P. E. Riley, K. B. Kunz, and K. Seff, *J. Am. Chem. Soc.*, **97**, 537 (1975).

(18) P. C. W. Leung and K. Seff, Northwest Regional Meeting of the American Chemical Society, Honolulu, Hawaii, June 1975.

(13) K. Klier and M. Rálek, *J. Phys. Chem. Solids*, **29**, 951 (1968).

(14) V. Gramlich and W. M. Meier, *Z. Kristallogr., Kristallphys., Kristallchem.*, **133**, 134 (1971).

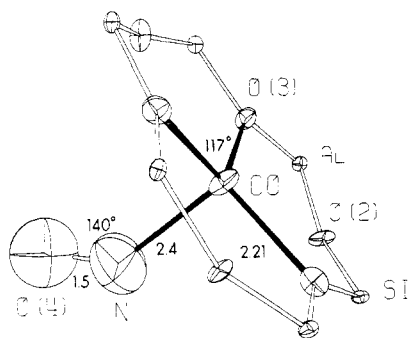

**Figure 8.** In the NO complex of  $\text{Co}_4\text{Na}_4\text{-A}$ , an NO molecule coordinates to each Co(II) in a bent manner. The zeolite has changed from deep blue to dark brown upon sorption, presumably forming Co(III) and  $\text{NO}^-$ . Ellipsoids of 20% probability are shown.<sup>6</sup>

precisely found to be  $\text{Co-N} = 2.4 \text{ \AA}$  and  $\text{N-O} = 1.5 \text{ \AA}$ . (In addition to estimated standard deviations in those values of nearly  $0.1 \text{ \AA}$ , a sensitivity a few times greater than that to the choice of least-squares weighting scheme and to the placement of the  $\text{Na}^+$  ions has been noted.) There is an interesting further indicator of the oxidation of Co(II): the oxide ions of the sodalite unit, which were initially in contact with four Co(II) and four  $\text{Na}^+$  ions (total charge = +12), would now be in contact with four Co(III) and four  $\text{Na}^+$  ions (total charge = +16). To relieve this localized charge imbalance, apparently, approximately 2.5  $\text{Na}^+$  ions have relocated to 8-ring sites. This effect was noted once before, in an attempted  $\text{N}_2$  complex<sup>19</sup> of  $\text{Co}_4\text{Na}_4\text{-A}$ , although satisfactory nitrogen positions could not be found.

Dehydrated Co(II)-exchanged zeolites catalyze the formation of  $\text{N}_2\text{O}$  and  $\text{NO}_2$  from NO. The mechanism for this process has been shown<sup>20</sup> to involve the initial formation of an  $\text{NO}^-$  complex of Co(III), the same as discussed in the previous paragraph, which is then attacked by a free NO molecule in the next step.

### Alkali-Metal Ion Forms

A tetrahedrally distorted pentagonal-dodecahedral arrangement of 20 water molecules was found in the large cavity of hydrated  $\text{Ca}_4\text{Na}_4\text{-A}$ ,<sup>21</sup> and the same arrangement, cubically distorted, was found in hydrated  $\text{Na}_{12}\text{-A}$ ,<sup>14</sup> the form in which zeolite A is synthesized. This arrangement of water molecules, which was found earlier in the structures of  $\text{Cl}_2\cdot 8\text{H}_2\text{O}$ <sup>22</sup> and those of other small-molecule hydrates<sup>23</sup> such as  $\text{Xe}\cdot 5.75\text{H}_2\text{O}$  and  $\text{CH}_4\cdot 5.75\text{H}_2\text{O}$ , was postulated by Pauling to be a transitory component of the structure of liquid water. The pentagonal dodecahedron has contributed to the stability of the hydrated zeolite and has allowed the relatively open aluminosilicate framework to form. Dehydrated zeolite A, whose empty channels and cavities (see Figure 1) comprise nearly half of the volume of the crystal, can be considered a fossil of its missing water structure. When ammonia is sorbed onto dehydrated  $\text{Na}_{12}\text{-A}$ ,<sup>24</sup> a similar pentagonal dodecahedron of 20  $\text{NH}_3$  molecules is found in the large cavity.

The water structure in hydrated  $\text{K}_{12}\text{-A}$ <sup>25</sup> has little in common with that of  $\text{Na}_{12}\text{-A}$ .<sup>14</sup> Eight  $\text{K}^+$  ions which form a large cube in the large cavity are bridged at each edge by a single water molecule (Figure 9). A small cube ( $2.85 \text{ \AA}$  along an edge) of eight water molecules (each  $2.85 \text{ \AA}$  from the nearest framework oxygen) is found in the sodalite cavity.

In hydrated and dehydrated  $\text{K}_{12}\text{-A}$ <sup>25</sup> and  $\text{Na}_{12}\text{-A}$ ,<sup>5</sup> eight cations are associated with 6-oxygen rings and three with 8-oxygen rings, filling those two equi-points. (Actually, the latter is only one-quarter occupied, but increasing the occupancy beyond that would require unreasonably close interionic contact distances:  $\text{Na}^+\text{-Na}^+ = 1.23 \text{ \AA}$  and  $\text{K}^+\text{-K}^+ = 0.80 \text{ \AA}$ .) In the hydrated structures,<sup>14,25</sup> the 12th cation is associated only with water molecules near the center of the large cavity. Upon dehydration,<sup>5</sup> the 12th  $\text{Na}^+$  selects a site on a 2-axis opposite a 4-ring in the large cavity (Figure 1). This result is of analytical importance because it fixes  $x$  in  $(\text{NaAl})_x\text{Si}_{24-x}\text{O}_{48}$  at 12, its maximum value according to Loewenstein's rule,<sup>26</sup> and of chemical interest because it shows an ion at the apex of a square pyramid whose base consists of four coordinating oxygens—an ion at such a position is particularly exposed to sorbed molecules and particularly coordinatively unsaturated.

The 12th  $\text{K}^+$  ion cannot select this site; the ionic radii of the  $\text{K}^+$  ions make it inaccessible ( $\text{K}^+\text{-K}^+$  would be approximately  $1.8 \text{ \AA}$ ). Accordingly, it occupies a most unusual site deep within the large cavity (see Figure 10) where it is *not* in ordinary contact with any other ion or atom in the structure.<sup>25</sup> The 12th  $\text{K}^+$  ion is at a relatively shallow potential energy minimum  $4.26 \text{ \AA}$  from three 6-ring oxygens,  $4.56 \text{ \AA}$  from the other three oxygens of the same 6-ring,  $4.80 \text{ \AA}$  from a  $\text{K}^+$  ion on the same 3-axis,  $4.91 \text{ \AA}$  from six nonsodalite oxygens, and  $5.53 \text{ \AA}$  from three  $\text{K}^+$  ions associated with adjacent 6-rings. The association number or liganacy of this 12th  $\text{K}^+$  ion is zero. The unusual sorptive properties of dehydrated  $\text{K}_{12}\text{-A}$  have led to its use in an inexpensive noncryogenic process for the preparation of up-to-95%-pure oxygen from air.<sup>27</sup>

In both hydrated and dehydrated  $\text{Cs}_7\text{Na}_5\text{-A}$ <sup>28</sup> the positions at the very centers of the 8-rings are fully occupied by  $\text{Cs}^+$  (three ions per unit cell). While most cation-to-framework approach distances in zeolites are somewhat less (ca.  $0.1$  to  $0.2 \text{ \AA}$ ) than the sum of the corresponding ionic radii, especially in dehydrated samples, each of these three  $\text{Cs}^+$  ions is  $0.3 \text{ \AA}$  further than this sum from its four nearest framework oxygens (see Figure 11). This unusual result is in full accord with ir results<sup>29</sup> which indicate an anomalously weak interaction between these  $\text{Cs}^+$  ions and the zeolite framework. The smaller univalent ions,  $\text{Li}^+$ ,  $\text{Na}^+$ ,  $\text{Ag}^+$ ,  $\text{K}^+$ , and  $\text{Tl}^+$ , all interact strongly with the zeolite (ir results<sup>29</sup>), and those which have been studied crystallographically ( $\text{Na}^+$ ,<sup>14</sup>  $\text{K}^+$ ,<sup>25</sup> and  $\text{Tl}^+$ <sup>30</sup>) are located in the 8-rings, but off-center, so as

(19) P. E. Riley, Ph.D. Thesis, University of Hawaii, 1974.

(20) K. A. Windhorst and J. H. Lunsford, *J. Am. Chem. Soc.*, **97**, 1407 (1975).

(21) K. Seff, Ph.D. Thesis, Massachusetts Institute of Technology, 1964.

(22) L. Pauling and R. E. Marsh, *Proc. Natl. Acad. Sci. U.S.A.*, **36**, 112 (1952).

(23) H. M. Powell, *J. Chem. Soc.*, 61 (1948).

(24) R. Y. Yanagida and K. Seff, *J. Phys. Chem.*, **76**, 2597 (1972).

(25) P. C. W. Leung, K. B. Kunz, I. E. Maxwell, and K. Seff, *J. Phys. Chem.*, **79**, 2157 (1975).

(26) W. Loewenstein, *Am. Mineral.*, **39**, 92 (1954).

(27) H. Lee, *Adv. Chem. Ser.*, **No. 121**, 311 (1973).

(28) T. B. Vance, Jr., and K. Seff, *J. Phys. Chem.*, **79**, 2163 (1975).

(29) I. E. Maxwell and A. Baks, *Adv. Chem. Ser.*, **No. 121**, 87 (1973).

(30) P. E. Riley, K. Seff, and D. P. Shoemaker, *J. Phys. Chem.*, **76**, 2593 (1972).

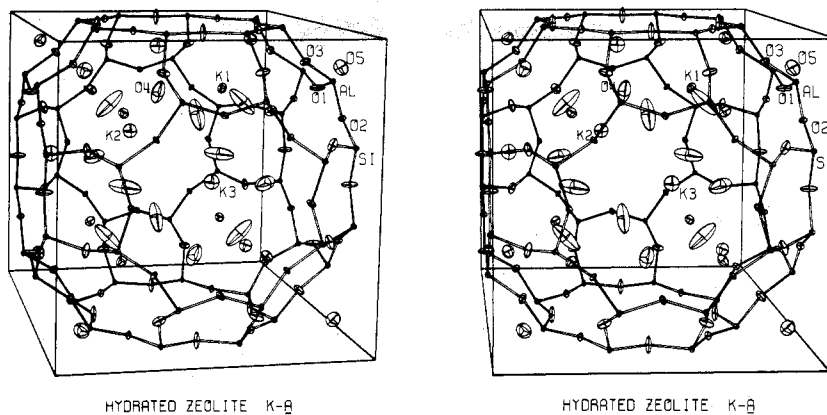

HYDRATED ZEOLITE K-8

HYDRATED ZEOLITE K-8

**Figure 9.** Stereoview of the large cavity of hydrated  $K_{12}$ -A using 20% probability ellipsoids. The eight ions at K(1) form a cube with one somewhat disordered water molecule at O(4) bridging along each edge.

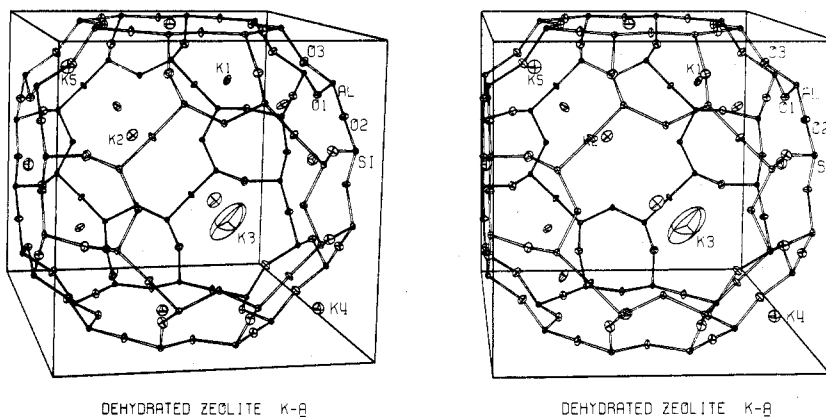

DEHYDRATED ZEOLITE K-8

DEHYDRATED ZEOLITE K-8

**Figure 10.** Stereoview of dehydrated  $K_{12}$ -A using ellipsoids of 20% probability.<sup>6</sup> The ion at K(3) can be considered zero-coordinate.

to have conventional approach distances to two 8-ring oxygens (see Figures 1 and 10). It appears that in  $Cs_7Na_5$ -A<sup>28</sup> four potential minima at  $0,x,x$ ;  $0,1-x,x$ ;  $0,x,1-x$ ; and  $0,1-x,1-x$  have coalesced to create a new minimum at  $0,1/2,1/2$ , the center of the 8-ring. The ir results for hydrated  $Rb_{8.3}Na_{3.7}$ -A<sup>29</sup> indicate that a weak interaction exists in this structure also, suggesting that Rb-O distances approximately 0.5 Å greater than the sum of the corresponding radii exist in the 8-rings. It appears that, in dehydrated  $Cs^+$ - or  $Rb^+$ -exchanged zeolite A, cations exist which are not in ordinary contact with any other atom or ion in the structure. A critical ionic radius between that of  $Tl^+$  (1.40 Å) and  $Rb^+$  (1.48 Å) is indicated. Clearly, this effect has a different basis and is less pronounced than that found in dehydrated  $K_{12}$ -A.<sup>25</sup>

### Apparent Ion-Exchange Limits

The apparent exchange limit of  $Cs^+$  for  $Na^+$  in zeolite A from aqueous 1.0 M  $CsCl$  at room temperature is seven (out of twelve).<sup>28</sup> Three  $Cs^+$  ions are found in the 8-rings, as just discussed, and the remaining four are associated with four of the eight 6-rings per unit cell. Presumably it is the half-utilization of these 6-rings, presumably four tetrahedrally placed 6-rings as illustrated in Figure 11, that is responsible for this exchange limit,

Similarly, the exchange limit for  $Mn(II)$ <sup>9</sup> or  $Co(II)$ <sup>7</sup> into  $Na_{12}$ -A appears to be 4.5 bivalent ions per unit cell. A selectivity plot for  $Zn(II)$  exchange into  $K_{12}$ -A indicates a wide plateau<sup>31</sup> at nearly the same compo-

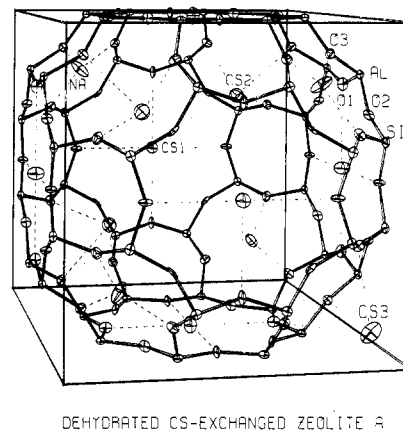

DEHYDRATED CS-EXCHANGED ZEOLITE A

**Figure 11.** Dehydrated  $Cs_7Na_5$ -A using ellipsoids of 20% probability.<sup>6</sup> The three  $Cs(1)$  ions per unit cell, located at the very centers of the 8-rings, are apparently 0.26 Å further from their nearest neighbors than the sum of the ionic radii of  $Cs^+$  and  $O^{2-}$ , and interact weakly with the framework.

sition. The structure of hydrated  $Mn_{4.5}Na_3$ -A<sup>9</sup> indicates the structural basis for this effect. A  $Na(H_2O)_3^+$  ion is found in the vicinity of each 8-ring. There are three 8-rings per unit cell, and only one such hydrated univalent cation can reasonably associate with each.

### Zeolite A as a Lewis Base

Iodine sorbed into dehydrated  $Ca_4Na_4$ -A does not associate with cations at all.<sup>32</sup> Instead,  $I_2$  molecules act as Lewis acids with respect to framework oxide

(31) T. Takaishi, Y. Yatsurugi, A. Yusa, and T. Kuratomi, *J. Chem. Soc., Faraday Trans.*, 71, 97 (1975).

(32) K. Seff and D. P. Shoemaker, *Acta Crystallogr.*, 22, 162 (1967).

ion lone pairs. Linear I-I-O sequences with  $I_2$  bonds lengthened by complexation, as are commonly found in halogen ( $X_2$ ) charge-transfer complexes, occur here. The hope of finding the geometry of a sorbed molecule altered by sorption, perhaps so as to indicate the mechanism of a catalytic process or the electronic basis of sorption, is realized in this complex.

### Concluding Remarks

The reader has noted, perhaps with some impatience, that only a few of the many available ions have been studied, and that only a few of the available molecules have been sorbed onto these zeolites. In some cases problems in exchange or sorption have

prevented further work, but many combinations remain to be studied at various cation and sorbate compositions, pressures, and temperatures, as interest in new problems develops. Reduced metal ions, and perhaps clusters of metal atoms, may be studied inside zeolites. In the general sense, the choice of zeolite framework and composition are other variables, although, as discussed earlier, imprudent choices may lead to poor results.

Zeolites are widely appreciated for their many uses. The basis for this utility, their remarkable intravoid chemistry, is just beginning to be understood, as is their capacity to teach us about unusual interactions of interest far beyond their own realm.

## Interpretation of Potential Constants: Application to Study of Bonding Forces in Metal Cyanide Complexes and Metal Carbonyls

Llewellyn H. Jones\*

*University of California, Los Alamos Scientific Laboratory, Los Alamos, New Mexico 87545*

Basil I. Swanson

*Chemistry Department, University of Texas, Austin, Texas 78712*

*Received December 5, 1974*

A clear understanding of the interatomic forces in molecules and complex ions, as well as the weaker crystal-lattice forces in solids, is of fundamental importance to chemists. While there are several experimental methods which help clarify our concepts of bonding, few probe interatomic forces directly.

Vibrational spectra, as observed by infrared absorption and Raman scattering, are direct manifestations of these forces. Interatomic forces can be expressed as force constants (or compliance constants, which may be more appropriate in some cases) which determine the vibrational frequencies of the system.

Llewellyn H. Jones received his Ph.D. degree at California Institute of Technology in 1950, working in infrared spectroscopy with Richard M. Badger. Except for 1 year as a postdoctoral student at the University of Rochester, he has been at the Los Alamos Scientific Laboratory since leaving Cal-Tech. His research has been mainly in the field of vibrational spectroscopy (infrared and Raman) directed toward an understanding of the interatomic forces in molecules and complex ions.

Basil I. Swanson received his B.S. degree from the Colorado School of Mines and his Ph.D. from Northwestern University in 1970. Before joining the chemistry faculty at the University of Texas at Austin, he was a postdoctoral fellow at Los Alamos Scientific Laboratories, and then Assistant Professor at New York University. His primary research interests concern structure and bonding in inorganic complexes, photoinduced solid-state reactions and displacive phase changes in crystalline solids.

Observation and correct interpretation of the vibrational frequencies, using infrared and Raman spectroscopy, can lead to an evaluation of the force constants which describe the details of bonding forces.

As a simple example, let us consider a diatomic molecule, AB. The force resisting distortion from the equilibrium bond length can, in general, be expressed as a power series in the displacement from equilibrium,  $X = R - R_e$ :  $f = -kX + lX^2 + \dots$ . The potential energy is then  $V = -\int f dX = \frac{1}{2}kX^2 - \frac{1}{3}lX^3 + \dots + V_0$ . The zero of potential energy is arbitrary, and thus the integration constant  $V_0 = 0$ . Near the equilibrium bond length terms higher than  $X^2$  can be neglected. We then have the potential function of a harmonic oscillator,  $V = \frac{1}{2}kX^2$ , with  $k$  the "quadratic" force constant at the equilibrium bond length. Solution of the equations of motion yields the relationship between the frequency of vibration,  $\nu$ , and the quadratic force constant,  $k = 4\pi^2\nu^2c^2\mu$ , where  $c$  is the velocity of light and  $\mu$  is the reduced mass  $[M_A M_B / (M_A + M_B)]$ . The direct relationship between  $\nu$  and  $k$  for diatomics has led to the use of frequencies of vibration as a direct probe of bonding in polyatomic molecules.